

AXIAL LEAD TAPING SPECIFICATIONS FOR RECTIFIERS

Axial lead devices are packed in accordance with EIA standard RS-296-D and specifications given below.

COMPONENT OUTLINE	COMPONENT PITCH A +/-0.5mm (.020")	INNER TAPE PITCH B +/-1.5mm (.059")	CUMULATIVE PITCH TOLERANCE
TS-1/A-405	5.0mm	26.0mm	2.0mm/20pitch
TS-1/A-405	5.0mm	52.4mm	2.0mm/10pitch
DO-41	5.0mm	52.4mm	2.0mm/10pitch
DO-15	5.0mm	52.4mm	2.0mm/10pitch
DO-201/DO-201AD/P2500	10.0mm	52.4mm	2.0mm/10pitch
R-6	10.0mm	52.4mm	2.0mm/10pitch
DO-34/DO-35/DO-41	5.08mm±0.4	26.0mm±0.5	2.0mm/20pitch
DO-34/DO-35/DO-41	5mm±0.3	52.25mm±0.25	2.0mm/10pitch

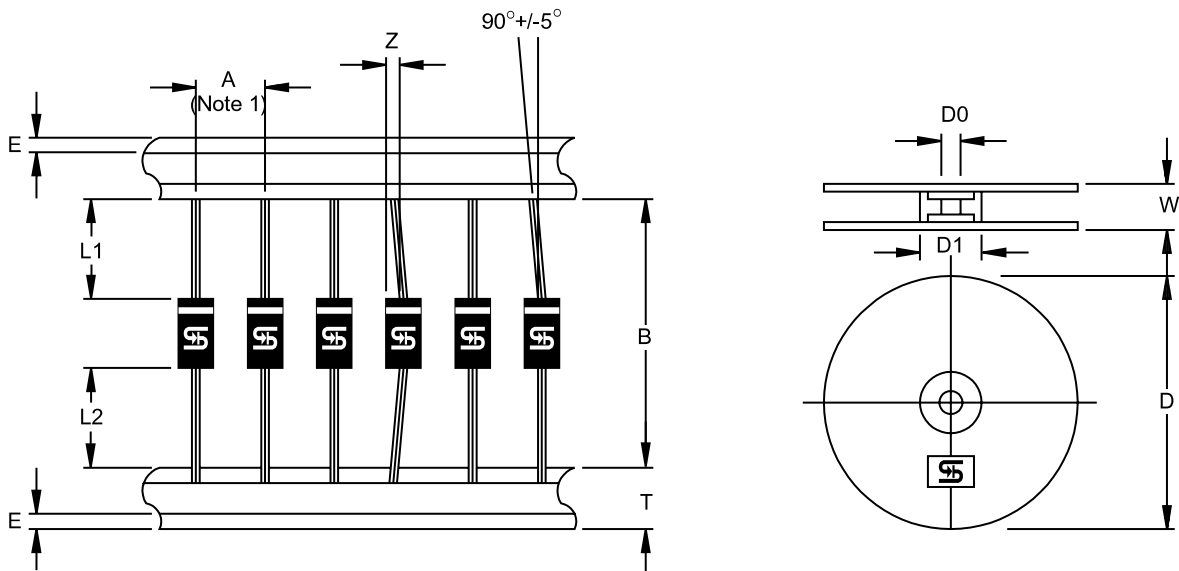

ITEM	SYMBOL	SPECIFICATIONS (mm)	SPECIFICATIONS (inch)
Component alignment	Z	1.2max	0.048max
Tape width	T	2.75~6.4	0.11~0.256
Exposed adhesive	E	0.8max	0.032max
Body eccentricity	L1-L2	±1.2	±0.048
Reel outside diameter	D	330~356	13.0~14.24
Reel inner diameter	D1	84~89	3.36~3.5
Reel hole diameter	Do	16.2~30.2	0.648~1.2
Reel width (Note2)	W	76.0±1.0	2.99±0.040

NOTE: 1. Each component lead shall be sandwiched between tapes for a minimum of 3.2mm(0.126")
 2. The reel width "W" for 26mm taping is 50 ±1.0m/m (1.97"±0.03")